

INSTRUCTION BOOK FOR

BIRD

MODEL 8790

TERMALINE[®] LOAD RESISTOR

LIMITED WARRANTY

All products manufactured by Seller are warranted to be free from defects in material and workmanship for a period of one (1) year, unless otherwise specified, from date of shipment and to conform to applicable specifications, drawings, blueprints and/or samples. Seller's sole obligation under these warranties shall be to issue credit, repair or replace any item or part thereof which is proved to be other than as warranted; no allowance shall be made for any labor charges of Buyer for replacement of parts, adjustment or repairs, or any other work, unless such charges are authorized in advance by Seller.

If Seller's products are claimed to be defective in material or workmanship or not to conform to specifications, drawings, blueprints and/or samples, Seller shall, upon prompt notice thereof, either examine the products where they are located or issue shipping instructions for return to Seller (transportation-charges prepaid by Buyer). In the event any of our products are proved to be other than as warranted, transportation costs (cheapest way) to and from Seller's plant, will be borne by Seller and reimbursement or credit will be made for amounts so expended by Buyer. Every such claim for breach of these warranties shall be deemed to be waived by Buyer unless made in writing within ten (10) days from the date of discovery of the defect.

The above warranties shall not extend to any products or parts thereof which have been subjected to any misuse or neglect, damaged by accident, rendered defective by reason of improper installation or by the performance of repairs or alterations outside of our plant, and shall not apply to any goods or parts thereof furnished by Buyer or acquired from others at Buyer's request and/or to Buyer's specifications. In addition, Seller's warranties do not extend to the failure of tubes, transistors, fuses and batteries, or to other equipment and parts manufactured by others except to the extent of the original manufacturer's warranty to Seller.

The obligations under the foregoing warranties are limited to the precise terms thereof. These warranties provide exclusive remedies, expressly in lieu of all other remedies including claims for special or consequential damages. SELLER NEITHER MAKES NOR ASSUMES ANY OTHER WARRANTY WHATSOEVER, WHETHER EXPRESS, STATUTORY, OR IMPLIED, INCLUDING WARRANTIES OF MERCHANTABILITY AND FITNESS, AND NO PERSON IS AUTHORIZED TO ASSUME FOR SELLER ANY OBLIGATION OR LIABILITY NOT STRICTLY IN ACCORDANCE WITH THE FOREGOING.

MODELS COVERED IN THIS INSTRUCTION BOOK

I N S T R U C T I O N B O O K

F O R

M O D E L 8 7 9 0

T E R M A L I N E[®] L O A D R E S I S T O R

BIRD
Electronic Corporation

30303 Aurora Road, Cleveland, Ohio 44139-2794

Copyright 1987 by Bird Electronic Corporation

SAFETY PRECAUTIONS

The following are general safety precautions that are not necessarily related to any specific part or procedure and do not necessarily appear elsewhere in this publication.

Keep away from live circuits.

Operating personnel must at all times observe normal safety regulations. Do not attempt to replace parts or disconnect a RF transmission or any other high voltage line while power is applied. When working with high voltage always have someone present who is capable of rendering aid if necessary. Personnel working with or near high voltage should be familiar with modern methods of resuscitation.

The following will appear in the text of this publication and is shown here for emphasis.

```
*****
*                               C A U T I O N                               *
*                               *                                           *
* The water flow must be kept in the right direction, *
* opposite flow will cause immediate burnout. *
*****
```

```
*****
*                               W A R N I N G                               *
*                               *                                           *
* When using dry cleaning solvents, provide adequate *
* ventilation and observe normal safety precautions. *
* Many dry cleaning agents emit toxic fumes that may be *
* harmful to your health, if inhaled. *
*****
```

```
*****
*                               W A R N I N G                               *
*                               *                                           *
* The resistor used in this load consists of a resistive *
* film on a special substrate. If the substrate is *
* broken, there will probably be sharp pieces or splin- *
* ters inside the load housing. Caution should be exer- *
* cised to avoid possible injury. *
*****
```

Continued

SAFETY PRECAUTIONS

```
*****
*                                     C A U T I O N                                     *
*                                     *                                               *
* Do not apply more than the RF power to the load. The *
* water flow rate and inlet temp. (5°C to 60°C) must be *
* as specified; viz., *
*                                     Gal/Min    Gal/Min *
*          kW   Model   at 5°C      at 60°C *
*          80   (8790)   9    to    12    (34 to 45.4 lpm) *
* In effect, adequate and uninterrupted full water flow *
* is more critical than temperature. *
*****
```

```
*****
*                                     C A U T I O N                                     *
*                                     *                                               *
* Be sure cooling liquid is flowing through the load *
* before RF power is applied and make sure the cooling *
* liquid supply is not interrupted while load is in oper- *
* ation. Even momentary interruption of coolant supply *
* while load power is applied will cause almost immediate *
* burnout. *
*****
```

```
*****
*                                     C A U T I O N                                     *
*                                     *                                               *
* Never reverse the cooling water connections. It is *
* very important for the safety of the load resistor to *
* observe proper flow direction. Also, when the load is *
* first installed or is reconnected, run the water for *
* approximately a minute to fill the system and remove *
* all bubbles before turning on the RF power. *
*****
```

```
*****
*                                     C A U T I O N                                     *
*                                     *                                               *
* DO NOT disconnect water flow switch leads from control *
* assembly. Any operation of the load without proper *
* functioning of cooling system will cause immediate *
* destruction of the resistor element. *
*****
```

TABLE OF CONTENTS

	<u>Page</u>
SAFETY PRECAUTIONS	i
INTRODUCTION	
General.....	v
Purpose and Function.....	v
Control System Option.....	v
Use as a Wattmeter.....	v
SECTION I - INSTALLATION	
General.....	1
Load Resistor Attachment.....	1
Water Line Attachment.....	1
Cooling Water Quality.....	1
Flow Switch (Optional).....	2
Control Box (Optional).....	2
PreOperational Checkout.....	2
SECTION II - THEORY OF OPERATION	
General.....	4
Heat Transfer.....	4
Cooling Water	4
Flow Interlock Control Circuit.....	5
SECTION III - OPERATION	
General.....	6
Operating as a Load Resistor.....	6
Operating as an RF Wattmeter.....	7
Shut-Down Procedure.....	7
SECTION IV - MAINTENANCE	
General.....	8
Cleaning.....	8
RF Load Resistor.....	8
Replacement Procedure for Resistive Element.....	8
Load Reassembly.....	11

Continued

TABLE OF CONTENTS

	<u>Page</u>
SECTION V - REPLACEMENT PARTS LIST	
Model 8790.....	16
TABLES	
Specifications.....	vi
ILLUSTRATIONS	
Load Ground Section.....	13
Load Midsection.....	14
Load Input Section.....	15

MODEL 8790 TERMALINE® COAXIAL RF LOAD RESISTOR

INTRODUCTION

GENERAL

The Model 8790 Load Resistor is carefully designed as a rather compact, and a very low-reflection, nonradiating termination for high power RF transmission lines. Cooled by integral water flow, it generates almost no ambient heat, making installation space minimal and convenient. It dissipates up to 80 kilowatts continuous power as used with the 50 ohm coaxial transmission lines.

PURPOSE AND FUNCTION

Model 8790 is particularly designed for direct coupling with 6-1/8 inch EIA flanged connectors, see Specifications. It maintains a VSWR of less than 1.5 from 1000Hz up to 800MHz. This model is intended for use on CW, AM, FM, SSB, and TV modulation envelopes, and within certain limitation on radar or pulse modes. Information on applications involving pulse-type signals should be obtained directly from Bird Electronic Corporation.

CONTROL SYSTEM OPTION

The equipment consists basically of the Load Resistor unit. An accessory protective Control System is available as optional equipment. When duly installed, this System protects the Load by shutting off RF power when water flow is too low or interrupted. Discussions of the flow control system in the Installation and Maintenance Sections herein should be ignored when not applicable. These models have the special feature of fairly simple field replacement of the resistors, as described in the Maintenance Section.

USE AS A WATTMETER

When used in conjunction with a Bird Model 4902 or 4905 Type THRULINE® Wattmeter, these load resistors may be used for direct reading of power measurements up to 80 kilowatts.

SPECIFICATIONS FOR MODEL 8790 TERMALINE® LOAD RESISTOR

Power Rating.....	80,000 Watts
Impedance.....	50 Ohms
Connector.....	6-1/8" EIA Flanged
Frequency Range.....	1000Hz to 800MHz
VSWR.....	1.15 maximum 1000Hz to 800MHz
Modes.....	CW, AM, FM, SSB, TV, and certain pulse types
Input water temperature range.....	5°C to 60°C (41°F to 140°F)
Minimum water flow rate.....	9GPM @ 5°C - 12 GPM @ 60°C (34 to 45.4 liter)
Water Connections.....	3/4" Standard hose thread
Weight.....	27 lbs. (12.3kg)
Dimensions	
Housing only.....	Maximum length - 35-1/8" Diameter - 3-1/2" (892.2 X 88.9mm)
Overall (with water connector).....	Maximum length - 36-7/16" Diameter - 8-1/8" (925.5 X 206.5mm)
Housing Material.....	Aluminum alloy & brass
Finish.....	Black lusterless enamel
RF Connector & Hose Nipples.....	Bright nickel plate

SECTION I - INSTALLATION

1-1. GENERAL

1-2. The design of the Model 8790 enables the load to be installed in restricted spaces. It requires no ventilation and may be placed at any attitude. Do not install where subject to severe vibration or to physical shock.

1-3. The load is ready for connection as received from the factory. It is useful to check 50 ohm input resistance of load before attachment, see Section IV - Maintenance.

1-4. Clean all conductors and insulator surfaces on transmission line face if required and check RF input connector. Use any good dry cleaning solvent on a clean cloth to clean connectors.

1-5. LOAD RESISTOR ATTACHMENT

1-6. Attach the load resistor to the 50 ohm, 6-1/8 EIA flanged RF line, but do not tighten. Use 6-1/8 inch EIA coupling kit, P/N 4902-020 which includes (12) 3/8-16 x 1-3/4 bolt sets, O-ring, and anchor bullet (center conductor).

1-7. Rotate the load so that Warning Label shows and the OUTLET water tube is placed to best advantage. Tighten RF connection, securing the clamps or bolt sets firmly and evenly.

1-8. Do not disturb socket head cap screws joining connector section to main housing.

1-9. WATER LINE ATTACHMENT

```
*****
*                               C A U T I O N                               *
*                               *                                           *
* The water flow must be kept in the right direction,                    *
* opposite flow will cause immediate burnout.                             *
*****
```

1-10. The RF load comes supplied with standard 3/4 inch hose fittings. The water INLET, at the back on center and water OUTLET adjacent, at 90° to INLET mate with 3/4 inch water hose connectors. The water flow switch is installed in the water INLET line, see Paragraph 1-13 below. For rigid pipe connections, replace both the water INLET and OUTLET hose adapters, P/N 5-065-2 with 1/2 inch male pipe or pipe fittings.

1-11. COOLING WATER QUALITY

1-12. Water quality is important. Refer to Paragraph 2-7 - Theory, for explanation and description. In general, any potable water is satisfactory. This would include: purified, filtered city supply or soft water, demineralized.

1-13. FLOW SWITCH (OPTIONAL)

1-14. The ports of the flow switch are 3/4 inch NPT Female. The direction of flow is marked on the casting of the flow tube and on the operating head - observe carefully; opposite connection will restrict water flow and cause load failure. The flow switch may be connected to the inlet or the outlet pipe of the load, but be certain the flow through the switch is in correct direction. Connect with 1/2 inch NPT nipple and 1/2 inch to 3/4 inch bushing, P/Ns 5-489-1 and 5-490-1. Or connect by hose or pipe, with the flow switch not over 20 feet from load. Attach hose to switch with 3/4 inch hose nipple, P/N 5-903. Do not connect flow switch leads at this time. Turn on water and check system for leaks and operation.

1-15. CONTROL BOX (OPTIONAL)

1-16. The wiring center and remaining elements of the control system are contained in the control box. This includes the terminal strip and three "BX" cable clamps for the input connections, a pilot lamp and the delay timer. Only wiring material is needed. The unit operates on either 115V ac for P/N 8750-115 or 230V ac for P/N 8750-230. The pilot lamp atop the box is a "safe operation" signal; it lights only when ac power is on and adequate water supply is flowing. After pilot goes "on", a 12±2 second time delay allows time for water flow to stabilize before closing transmitter interlock.

1-17. The control box is mounted through four 1/4 inch holes on 5 x 5 inch square in the back. Position it for best view of the pilot light and easy attachment of the "BX" cable and wiring. Connect leads - for both voltages - as depicted on the wiring schematic inside your control box. Note - These connections are critical - wire carefully, as follows.

- a. Water flow switch leads to terminals 3 and 5.
- b. Interlock switch leads to 6 and 7.
- c. AC power to 2 and 3 for 115V or 230V operation.

1-18. PREOPERATIONAL CHECKOUT

1-19. BEFORE ATTEMPTING TO OPERATE THE RF LOAD either under test or actual operating conditions, TEST the complete water system and INTERLOCK CONTROL as follows:

- a. Make sure ac and transmitter interlock power are OFF.
- b. Connect an ohmmeter across terminals 6 and 7; (INTERLOCK).
- c. Turn ac power on.
- d. Turn water supply on and note when water flow switch operates (audible click).
- e. In not less than 10 seconds (12±2) the ohmmeter reading on 6 and 7 should drop, indicating operation of the time delay switch.

f. Water flow from water OUTLET connection of the load must be not less than 9 to 12 gallons per minute. See Section III - Operating Instructions.

1-20. As a precautionary measure, the preoperation checkout should be performed each time the load is to be put into service.

SECTION II - THEORY OF OPERATION

2-1. GENERAL

2-2. This TERMALINE® Coaxial Load Resistor is unique in that it employs primarily external water cooling of the resistor element. By using this technique, the need for an intermediate dielectric fluid to transfer the heat generated in the resistor element has been eliminated, reducing the physical size of the load to virtually a minimum. This simplified system allows use of the loads in more varied environments, and attachment to lines at any attitude.

2-3. HEAT TRANSFER

2-4. The Model 8790 Load Resistor is novel in employing two separate resistor units arranged in a coaxial line. The two 25 ohm resistors consist of high temperature substrate tubes with a vacuum deposited resistive film. The heat generated by absorption of RF power is transferred from the heated films to the water flowing over it - through a restricted chamber surrounding the resistor body. This water, first conducted to the front of the load resistor, passes over the entire length of the resistors and discharges through the sealed water chamber at the rear. The dielectric characteristics and distinctive design of these enclosures provide a very accurate 50 ohm termination over the specified frequency range of this load - 1000Hz to 800MHz.

2-5. The absence of intermediate cooling fluids considerably simplifies the construction and sealing of this unit. It can be readily disassembled in the field for resistor element replacement, see Section IV - Maintenance.

2-6. Because there is practically no heat transfer from the outer housing of the load (it remains at ambient temperature even under full power) virtually all of the power input to the load is transformed into heat which is carried away by the cooling water; therefore, the differential in output and input temperatures of the water multiplied by the amount of flow constitutes a very accurate gauge of the power consumed by the load. The amount of this power dissipation may be calculated from the following formula:

$$P = 0.263 (T_1 - T_2) \text{ GPM}$$

Where:

P = Power in kilowatts
T₁ = Outlet water temperature in °C
T₂ = Inlet water temperature in °C
GPM = Water flow in gallons per minute

In °F the formula is : $P = .146 (T_1 - T_2) \text{ GPM}$

2-7. COOLING WATER

2-8. The electrical performance of this RF load is affected by impurities of other chemical additives in the water. The presence of salts in the

water definitely make the device unusable because of its causing sharp increase in VSWR. Therefore, sea water or silty water should not be used for cooling the loads.

2-9. The thermal performance of this load is affected by impurities, particularly those impurities that accumulate in the form of scale on the exposed surfaces of the water-conducting members of the load assembly. This may result in an increase in the thermal and/or fluid resistance(s) of the load and in turn cause the load to overheat and fail.

2-10. The following types of water are considered safe for the cooling of the Model 8790 Load: purified, filtered, city, or soft water (demineralized). In general, any potable water is suitable for cooling the load. Standards for "potable" water have been established by the U.S. Public Health Service at a maximum of 500 ppm of total dissolved solids (ppm - parts per million or 1 mg per liter). Hardness of water (content of calcium and magnesium salts) is also an essential factor, and should be less than 75 ppm.

2-11. FLOW INTERLOCK CONTROL CIRCUIT

2-12. The interlock control circuit provides instantaneous fail-safe protection of the transmitter and load in the event of even momentary interruption of the cooling water supply. This protection is necessary because dissipation of the heat generated by the RF power absorption is critically dependent upon a required minimum water flow regardless of inlet water temperature.

2-13. The water flow switch, attached to the water inlet of the load, is factory calibrated to open the electrical contacts whenever water flow drops below nine gallons per minute and close when water flow exceeds this value. When the water flow switch contacts open, the time delay relay switch is deactivated, which in turn, opens the interlock switch causing immediate shutdown of the transmitter or other signal source. The time delay switch also keeps the interlock switch "open" for an interval of 12 ± 2 seconds after the minimum flow of nine gallons per minute has been reestablished. This safeguarding feature is to assure proper operation of the cooling system before RF power can be applied to the load, preventing damage or burnout of the resistor element.

2-14. The control assembly also includes a large, torpedo-lens pilot light set on top of the box. As normally mounted, this red pilot lamp should be freely visible from nearly all front angles in the operating vicinity of the load unit/control assembly. After proper installation, described in Section I, lighting of this pilot lamp will serve as visible indication that the RF load is ready to receive power, or of trouble in the cooling supply (control) if it is not lighted.

SECTION III - OPERATION

3-1. GENERAL

3-2. The TERMALINE® RF Load is not equipped with any operating controls, therefore, the presence of an operator is not required while in use. Proper operation of the equipment is assured if the instructions contained in Section I - Installation are followed exactly.

```
*****
*                                     C A U T I O N                                     *
*                                                                                       *
* Do not apply more than the RF power to the load. The                               *
* water flow rate and inlet temp. (5°C to 60°C) must be                             *
* as specified; viz.,                                                                 *
*                                                                                       *
*           kW   Model   Gal/Min   Gal/Min                                           *
*           80   (8790)   at 5°C    at 60°C                                           *
*           9    to     12    (34 to 45.4 lpm) *
* In effect, adequate and uninterrupted full water flow                             *
* is more critical than temperature.                                                 *
*****
```

```
*****
*                                     C A U T I O N                                     *
*                                                                                       *
* Be sure cooling liquid is flowing through the load                               *
* before RF power is applied and make sure the cooling                             *
* liquid supply is not interrupted while load is in oper-                          *
* ation. Even momentary interruption of coolant supply                             *
* while load power is applied will cause almost immediate                          *
* burnout.                                                                           *
*****
```

```
*****
*                                     C A U T I O N                                     *
*                                                                                       *
* Never reverse the cooling water connections. It is                               *
* very important for the safety of the load resistor to                             *
* observe proper flow direction. Also, when the load is                           *
* first installed or is reconnected, run the water for                             *
* approximately a minute to fill the system and remove                             *
* all bubbles before turning on the RF power.                                       *
*****
```

3-3. OPERATING AS A LOAD RESISTOR

- a. Turn on ac power.
- b. Turn on water supply.
- c. Turn on interlock supply.

d. Check that all coaxial power line connections are properly tightened.

e. Apply RF power to load. Proceed according to instructions pertaining to the specific transmitting equipment.

3-4. OPERATING AS AN RF WATTMETER

3-5. The RF load can be combined with a Bird rigid line series THRULINE® to form an absorption-type wattmeter by inserting the wattmeter line section just ahead of the RF load. Installation and operation of the wattmeter is covered in the THRULINE® Instruction Book. Note - Select a wattmeter model that is appropriate for the input connector of the load resistor - consult Bird catalog.

a. Proceed with operating function the same as in Paragraph 3-3.

b. Rotate element in THRULINE® to monitor incident or reflected power. Measurement is taken in direction indicated by ARROW on element.

3-6. SHUT-DOWN PROCEDURE

a. Turn off RF power to load.

b. Wait at least one minute.

c. Turn off interlock ac power.

d. Turn off water supply - always do this last.

```
*****
*                               C A U T I O N                               *
*                               *                                           *
* DO NOT disconnect water flow switch leads from control *
* assembly. Any operation of the load without proper *
* functioning of cooling system will cause immediate *
* destruction of the resistor element. *
*****
```

SECTION IV - MAINTENANCE

4-1. GENERAL

4-2. The TERMALINE® Coaxial Load Resistor is rugged and simple, requiring only nominal and routine attention. The load is designed to operate for long periods of time if care is taken not to exceed its power handling capabilities. Always handle the load with care to prevent subsection to unnecessary shock or impact.

4-3. CLEANING

```
*****  
*                               W A R N I N G                               *  
*                               *                                           *  
* When using dry cleaning solvents, provide adequate                 *  
* ventilation and observe normal safety precautions.                 *  
* Many dry cleaning agents emit toxic fumes that may be           *  
* harmful to your health, if inhaled.                                 *  
*****
```

4-4. The outside surface of the unit should be wiped free of dust and dirt at regular intervals. Disconnect the instrument from the transmission line and clean the RF input connector, both metallic and insulator surfaces. Use an aerosol type contact cleaner or any dry cleaning solvent on a cloth for this purpose.

4-5. RF LOAD RESISTOR

4-6. Accurate measurement of the dc resistance between the inner and outer conductors of the RF input connector will provide a good check of the condition of the load resistor. For this measurement, a resistance bridge or ohmmeter with an accuracy of one percent or better at 50 ohms should be used. Use low resistance leads, preferably a short piece of 50 ohm cable. The measured resistance should not deviate more than 2 ohms from the value stamped on the manila tag attached to the load. It is recommended that this resistance check be performed each time the load is to be used.

4-7. REPLACEMENT PROCEDURE FOR RESISTIVE ELEMENT

4-8. This series of water cooled loads is designed to be quickly and easily repaired in the field. If in performing the dc resistance check described previously in Paragraph 4-6a significant change in resistance is noted, or if for any reason the resistive element should fail, inexpensive replacement resistors are available. They can be installed in the load using the following procedures:

Note - Part numbers designated by brackets [] in text following are so indicated on Figures 4-1, 4-2 and 4-3.

a. Load Removal

1. Shutdown the transmitter per manufacturers operating instructions. When the transmitter is completely inoperative, turn off the load cooling water.

2. Disconnect the two water hoses from the hose nipples [2] at the water chamber of the load.
 3. Remove the load from the transmission line by first loosening and removing the 3/8-16 x 1-1/2 bolts fastening the outer conductor swivel flange [29] to the flange of the line and then pulling the load away from the transmission line to disengage the center conductor bullet.
 4. Tip the water chamber end of the load down - in a suitable place - to drain any remaining water from the load.
- b. Resistor Removal -
1. Place the load on end with the water chamber [1] up.
 2. Firmly grasp the water chamber [1] with one hand and the housing of the load, just below the water chamber, with the other hand. Twist the water chamber in a counter-clockwise direction to loosen and unscrew the water chamber from the end of the ground section housing [9]. When the threads of the two parts are disengaged, remove the water chamber from the end of the ground section housing, as shown in Figure 4-1.
 3. The water inlet tube [4] (Figure 4-1) should either remain seated inside the water chamber or inside the end of the load, half exposed.
 - a. If the water inlet tube is in the water chamber, pull it out and visually inspect the water inlet tube [4], the inlet tube seal [5] and the water inlet seal [3], inside the water chamber [1], for possible damage. If these parts are in good condition, set them aside and continue with step 4 of this procedure below.
 - b. If the water inlet tube [4] remains in the end of the load, allow it to remain there and proceed to step 4.
 4. Remove the resistor cap assembly [7] from the ground section housing [9] by placing a screwdriver under the lip at the end of the resistor cap assembly and prying the resistor cap up about one-half inch. Then remove the resistor cap assembly the rest of the way by hand. Inspect the resistor cap assembly [7], the internal seal, resistor cap [8] and the rear seal, resistor cap [6] before setting the parts aside.
 5. Using a 3/16 inch Allen wrench, loosen and remove the six 1/4-20 x 1-3/4 inch socket head cap screws [20] from the 2nd housing section [11] , see Figure 4-2.
 6. Grasp the 2nd housing section [11], and by using a slight rocking motion, raise it from the front housing [19] approximately one-half inch. This will expose the teflon

junction insulator [17]. The junction insulator [17] should be kept in position inside the junction ring [25] - hold it in place with a screwdriver while continuing to remove the 2nd housing section [11].

7. The rear flow tube [12] should stay inside the 2nd housing section and the ground housing. Inspect the inside surface of rear flow tube. If it is undamaged and the inside of the 2nd housing section is dry, proceed to step 8. However, if the rear flow tube is damaged, unscrew the ground section housing [9] from the 2nd housing section [11] and pull the rear flow tube [12] out of the ground section housing. Inspect the ground section seal [10] and replace if necessary. Replace the rear flow tube [12], small outside diameter end first, in the ground section housing, see Figure 4-2. Then screw the ground section housing [9] onto the end of the 2nd housing section [11] and tighten securely.
8. Remove the exposed rear resistor [13] and remove the water inlet tube [4] from the resistor if it was not removed in step 3. Visually inspect the resistor for obvious damage then measure its resistance. The resistance should be 25 ohms plus or minus one ohm. If the resistance measures outside these limits, the resistor should be replaced.
9. Remove the junction ring [25] and insulator [17] by pulling straight off with a slight rocking motion. Pull the junction insulator [17] out of the junction ring [25] and inspect the junction insulator O-ring seals [18]. Then remove the resistor contact assembly [16] and inspect the spring contacts at each end. The spring contacts should not be either burned or flattened.
10. Loosen and remove the six 1/4-20 x 1 socket head cap screws [20] that hold the front housing [19] to the outer conductor assembly [28], as shown in Figure 4-3. Then lift the front housing off of the outer conductor assembly.
11. Hold the input insulator [24] down and pull the front flow tube [21] out of the insulator. Now remove the front resistor [13] from the resistor fitting [22] and check the resistor as described in step 8, above. The resistor junction tube [14] will be in the end of either this resistor or the resistor that was removed in step 8.
12. At this stage, the resistor junction tube should be removed from the end of the resistor and the resistor junction seals [15] should be inspected.
13. Lift the input insulator [24] out of the outer conductor assembly [28] - the remaining parts may be inspected without further disassembly. If any of the remaining parts are damaged, they can be released by removing the 3/8-16 x 3/4 hex head machine screw and split lock washer [27] as shown in Figure 4-3.

4-9. LOAD REASSEMBLY

a. Load Input Section, Figure 4-3.

1. Position the resistor fitting seal [23] in the groove in the resistor fitting [22] then insert the shaft of the resistor fitting into the hole in the center of the input insulator [24] and slide the resistor fitting into the insulator until it bottoms at the edge of the groove in the end of the insulator.
2. Place the input insulator [24] on the end of the center conductor assembly [26]. Fasten the parts together by inserting and securely tightening the 3/8-16 x 3/4 hex head machine screw and split lockwasher [27] as shown in Figure 4-3.
3. Position the outer conductor assembly [28] on end with the tapped holes facing up and insert the assembled parts from step 2 above, center conductor assembly first, into the recess in the end of the outer conductor assembly.
4. Place terminal of one the resistors [13] (either of the resistors can be used) into the inside of resistor fitting and slide the resistor to bottom in the fitting. The resistor should fit snugly in the fitting. If the fit is loose, carefully close the fingers of the resistor fitting until a snug, even fit is achieved.
5. Lower the front flow tube [21], larger outside diameter end first, over the resistor and press it into the groove in the input insulator [24]. Then lower the front housing [19] over the front flow tube and set the flange of the front housing on the end of the outer conductor assembly [28]. Fasten the front housing to the outer conductor assembly with six 1/4-20 x 1 socket head cap screws [20] and tighten securely.

b. Load Midsection, Figure 4-2.

1. Place the resistor junction seals [15] into the grooves in the resistor junction tube [14] and then slide either end of the resistor junction tube into the exposed end of the resistor [13] and press the junction tube to shoulder on the end of the resistor.
2. Press the resistor contact assembly [16] into the end of the front flow tube [21] until it bottoms. Replace the spacer [30] and junction ring [25], then install the junction insulator seals [18] and then press the junction insulator [17] into the recess in the end of the junction ring [25]. Insure that the junction insulator bottoms by twisting it while pressing down on it with the palm of the hand.

3. Insert the end of the remaining resistor [13] into the exposed end of the resistor contact assembly [16], and press it to bottom. Then lower the ground section housing [9], the 2nd housing section [11] and the rear flow tube [12] over the resistor, and rest the flange of the 2nd housing section on the end of the front housing junction ring [25]. Note - parts [9], [11] and [12] should already be assembled. If not, see step 7, of Paragraph 4-8b. of this procedure.
 4. Fasten the housing sections together by inserting six 1/4-20 x 1-3/4 inch socket head cap screws and securely tighten them using a 3/16 Allen wrench.
- c. Load Ground Section, Figure 4-1.
1. Replace the internal seal, resistor cap [8] in the groove inside the resistor cap assembly [7]. Then slide the end of the resistor cap assembly, with the internal O-ring seal, into the ground section housing [9]. Apply firm downward pressure on the end of the resistor cap assembly and it will snap into position.
 2. Replace the rear seal, resistor cap [6] in the groove in the exposed end of the resistor cap assembly [7] (See Figure 4-1). Replace the inlet tube seal [5] in the groove in the end of the water inlet tube [4] then press the seal end of the water inlet tube into the end of the resistor to shoulder.
 3. Reposition the water inlet seal [3] in the groove on the inside of the water chamber [1], then lower the water chamber over the end of the water inlet tube [4] and onto the threaded end of the ground section housing [9] screw the water chamber onto the ground section housing and tighten it thoroughly.
 4. Check the resistance between the inner and the outer conductors at the input of the load. If the load is properly assembled, the resistance will be approximately 50 ohms. Reconnect the cooling water hoses to the hose nipples [2] at the water chamber [1] and turn on the water. Check carefully for leaks. If the load resistance is about 50 ohms and if no leaks appear, the load resistor is ready for use.

Figure 4-1. Load Ground Section.

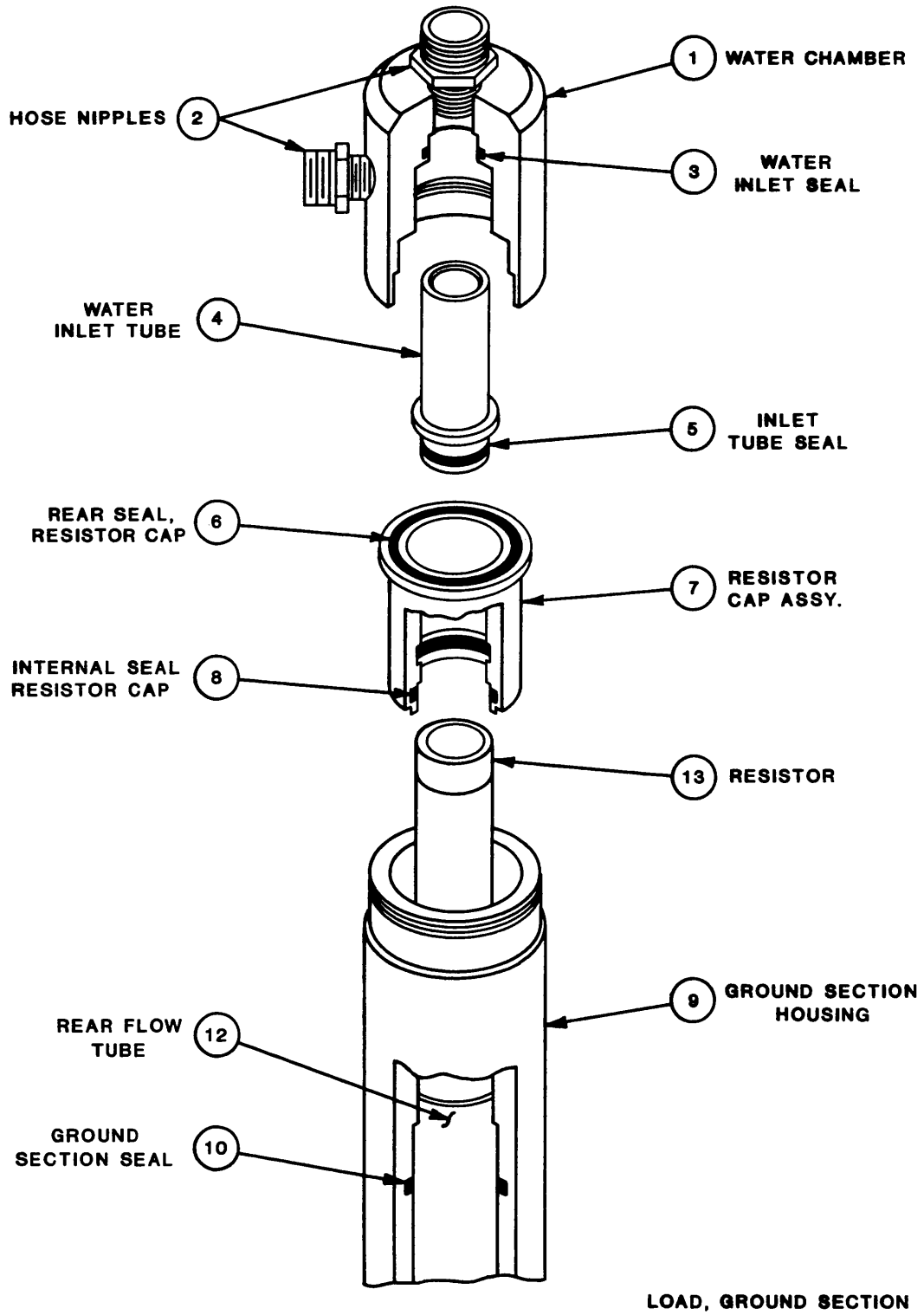
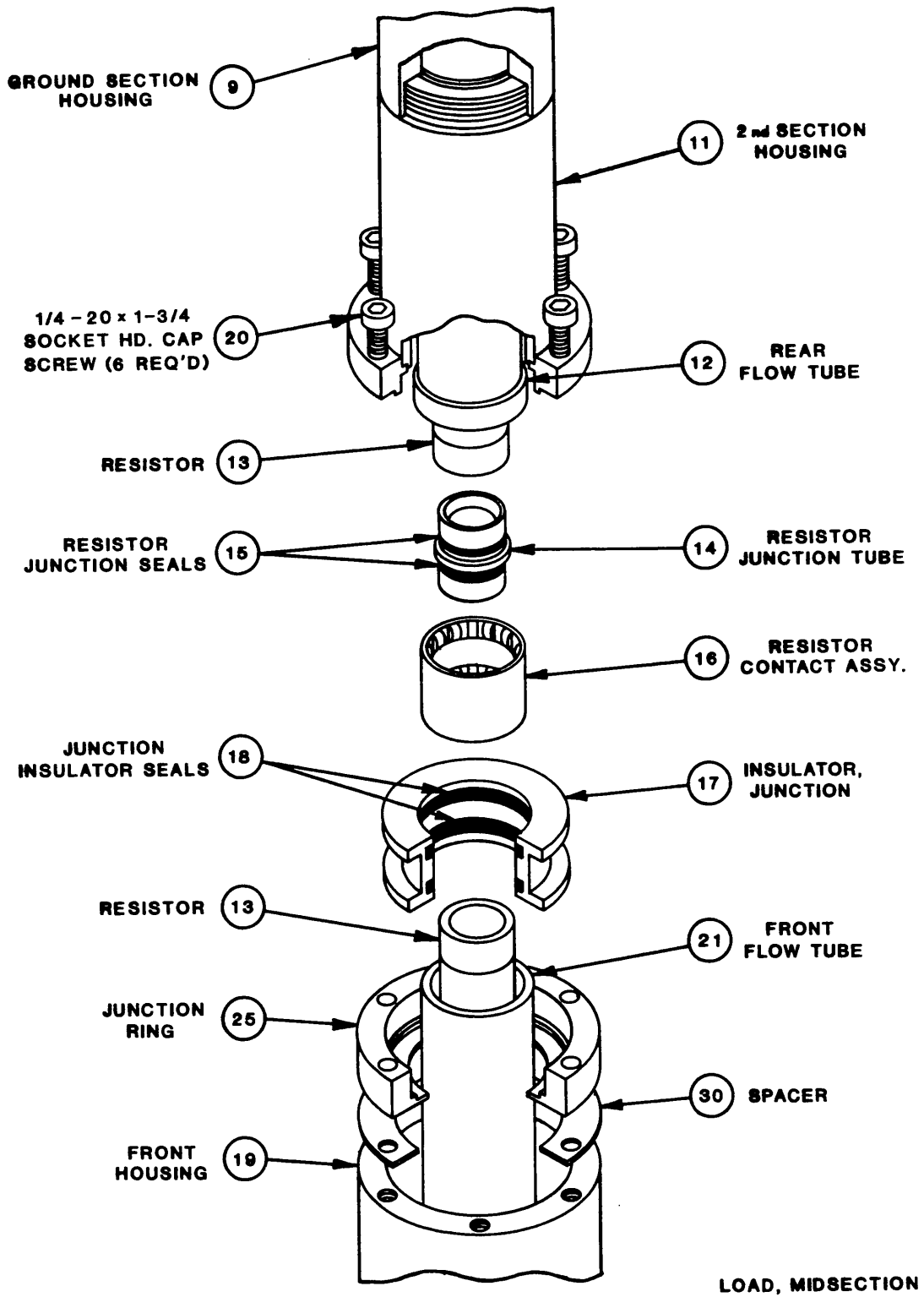
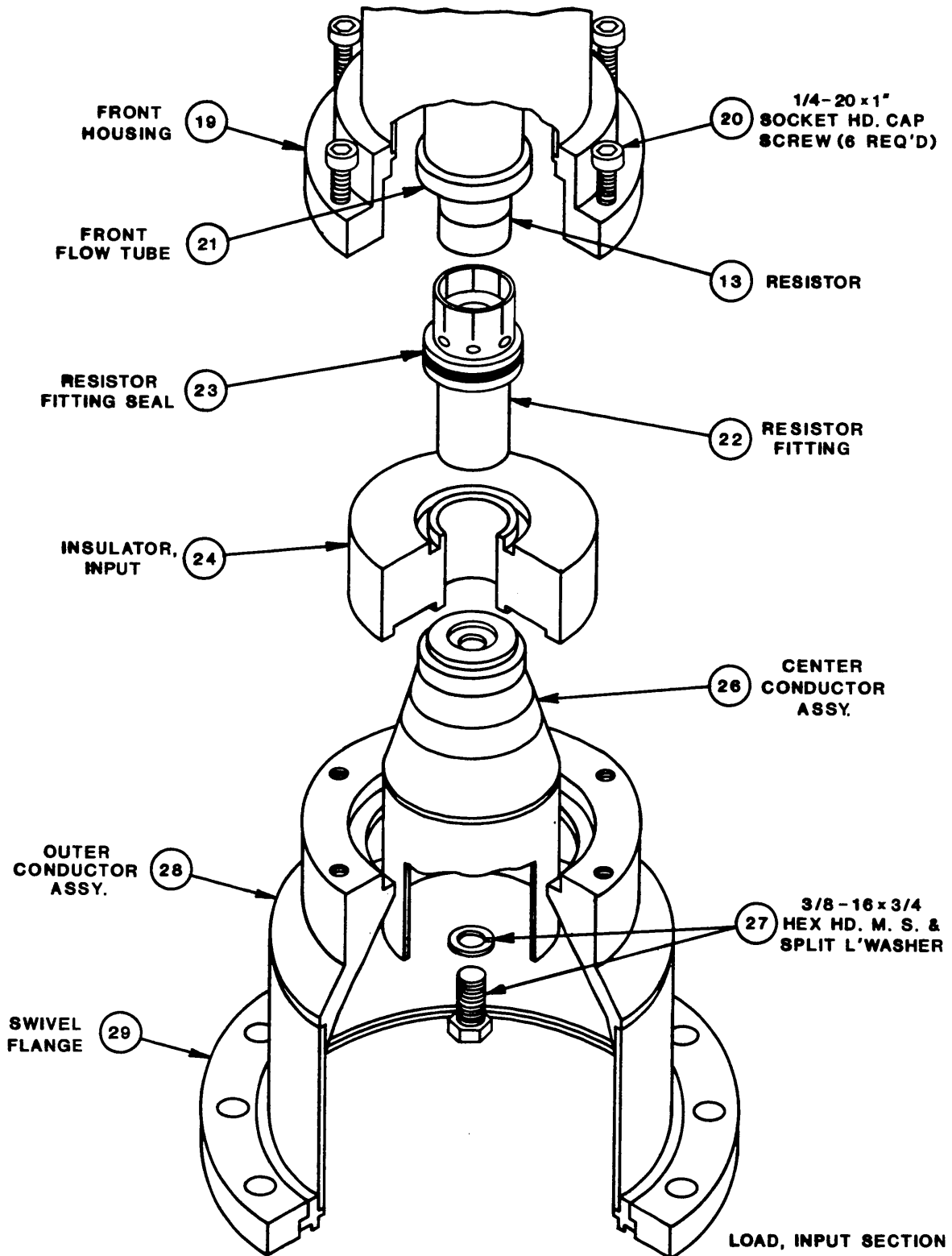

Figure 4-2. Load Midsection.



LOAD, MIDSECTION

Figure 4-3. Load Input Section.



SECTION V - REPLACEMENT PARTS LIST

5-1. MODEL 8790

ITEM	QUANTITY	DESCRIPTION	PART NUMBER
	1	Water Chamber Assembly, Consisting of:	8790-005
1		Water Chamber	8790-031
2	2	Hose Nipple	5-065-2
3	1	Seal, O-Ring, Internal	5-1250
4	1	Water Inlet Tube	8790-032
5	1	Seal, O-Ring, Water Inlet Tube	5-080
6	1	Rear Seal, O-Ring, Resistor Cap	5-1128*
	1	Resistor Cap Assembly	8790-004
7	1	Resistor Cap Subassembly	8790-011
8	1	Seal, O-Ring, Internal, Resistor Cap	5-1251
9	1	Housing, Ground Section	8790-033
10	1	Seal, O-Ring, Ground Section	5-1128*
11	1	Housing, Second Section	8790-003
12	1	Flow Tube, Rear	8790-034
13	2	Resistor (Front & Rear)	8790-035
14	1	Resistor Junction Tube	8790-019
15	2	Seal, O-Ring, Resistor Junction	5-080
16	1	Resistor Contact Assembly	8790-008
17	1	Insulator, Junction	8790-020
18	2	Seal, O-Ring, Insulator	5-1128*
19	1	Housing Assembly, Front Section	8790-007
20	12	1/4-20 x 1 Socket Head Cap Screw	Standard
21	1	Flow Tube, Front	8790-021
	1	Center Conductor, Input Assembly	8790-009
22	1	Fitting, Resistor	8790-016
23	1	O-Ring, Resistor Fitting	5-1127
24	1	Insulator, Input	8790-015
25	1	Junction Ring	8790-022
26	1	Center Conductor Assembly	8790-010
27	1	3/8-16 x 3/4 Hex Head Machine Screw	Standard
28	1	Outer Conductor Assembly	8790-006
29	1	Flange, Swivel	4902-014
30	1	Spacer	8790-042